Catalog

Pagination		Pagination	
Announcements	2	Maintain.....	11
Operation	3	Maintenance list.....	12
Machine Component	3	Battery Maintenance.....	13
Controls and Instrumentation.....	4	Motor Maintenance	13
Machine Working Principle.....	5	Replacement Brush.	14
Scrubbing Method	5	Replace Rubber strip	14
Machine Settings	6	Absorbent Steak After Adjustment	15
Assembly	6	Sewage Tank Sealing Maintenance	16
Mounting Brush.....	6	Tire Maintenance.....	16
Water Injection.....	7	Transport Machine.....	17
Before Machine Operation.....	7	Storage Machine.....	17
Floor Washing Operation.....	8	Specification	18
Discharge Of Sewage	9	Machine Specification.....	18
Battery Charging	9	Dimensions	19
Trouble Removal.....	10		

Matters need attention

Important Safety Notes - Keep them safe

The following symbols and instructions are used in this manual:



Warning: Used to warn of risks or unsafe operations that could result in serious injury or death

For safety: Indicate the things that must be observed when using the machine to ensure safety. The following information identifies situations that may pose a danger to the operator. Know when these situations are likely to occur.

Warning: The battery will release hydrogen, which may cause a fire or explosion.

Keep away from sparks or open fire sources. Keep the cap open when charging.



Warning: The battery will release hydrogen, which may cause a fire or explosion. Keep away from sparks or open fire sources. Keep the cap open when charging.



Warning: Flammable materials may cause an explosion or fire. Do not use flammable substances in the tank.



Warning: Flammable materials or active metals may cause an explosion or fire. Do not pick.

security measure

1. Do not operate the machine under the following circumstances:

- Not trained or authorized.
- Failure to read and understand the operator manual.
- After ingesting alcohol or drugs
- While using a cell phone or other type of electronic device
- Mental failure to follow machine guidelines
- Stop braking.
- Not in proper working condition.
- Located in areas where flammable vapors/ liquids or flammable dust are present.
- Located in an area where it is dark and it is not safe to view the controls or operate the machine, unless the lights are being operated or have been turned on.
- Possible area of falling objects unless covered.

2. Before operating the machine:

- Check the machine for liquid leaks.
- Keep sparks and open flames away from refueling areas.
- Make sure all safety equipment is in place and working properly.
- Check that the brakes and steering are working properly.
- Adjust the seat and fasten the seat belt (if equipped).

W3. When using the machine:

- Use only according to the instructions in this manual.
- Use the brake to stop the machine.
- Walk slowly on slopes and smooth surfaces.- Slow down when turning.
- When the machine is running, ensure that the operator's entire body is in the console.
- Be careful when reversing the machine.
- Children are not allowed to play on or near the machine.
- No passengers on the machine.
- Always obey safety and traffic rules.
- Report machine damage or malfunctioning immediately.
- Follow mixing, handling and disposal instructions on chemical containers
- Follow the safety guidelines for wetland boards.
- Follow site safety guidelines for wet panels.

4. Before leaving or repairing the machine:

- Park on a level surface.
- Turn off the machine and remove the key.

5. When repairing the machine:

- All work must be carried out in an environment with good lighting conditions and high visibility.
- Avoid moving parts. Do not wear loose clothing or jewelry, will Tie up long hair.
- Pick up the machine and stick the machine tire.



For safety reasons wear hearing protection.



For safety reasons Wear protective gloves.



For safety reasons Wear eye protection.



For safety reasons Wear a dust mask.

6. When loading the machine onto or off a truck or trailer:

- Empty water tank before loading machine.
- Lower the floor brush head and absorbent before turning off the machine
- Turn off the machine and remove the key.
- Use a ramp, truck or trailer that can support the weight of the machine and operator.
- Use a winch. Do not push the machine onto/off the truck or trailer unless the loading height is less than 380mm(15in.) from the ground.
- Stuck machine tires.
- Attach the machine to a truck or trailer.

Machine component

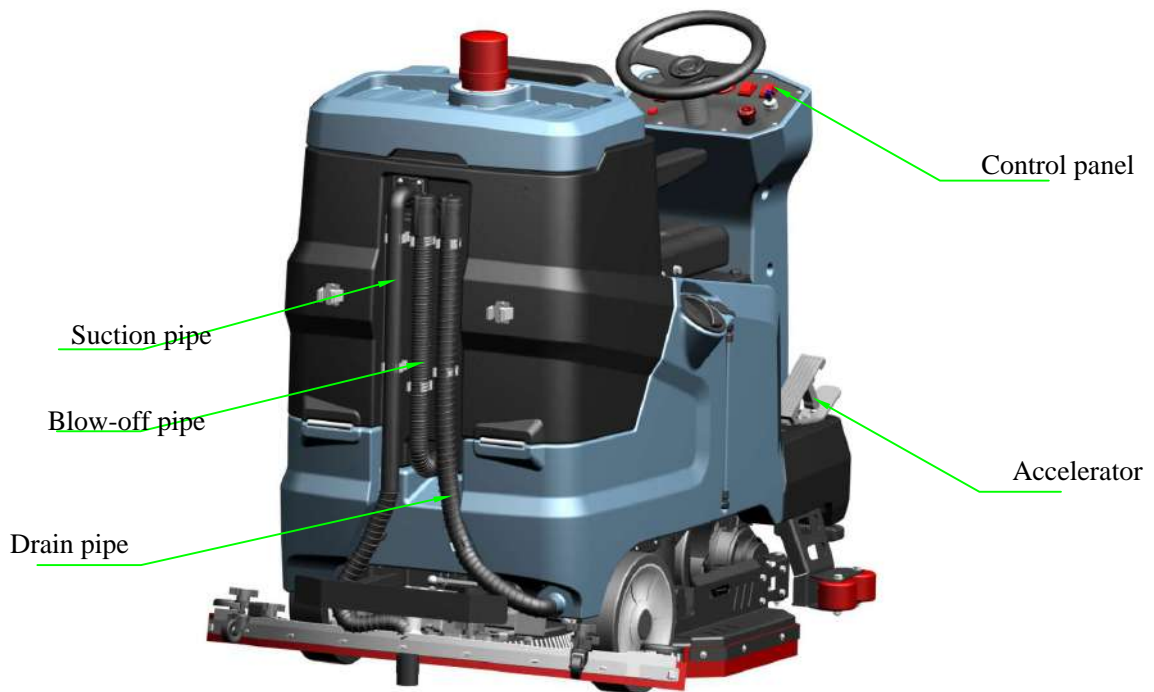
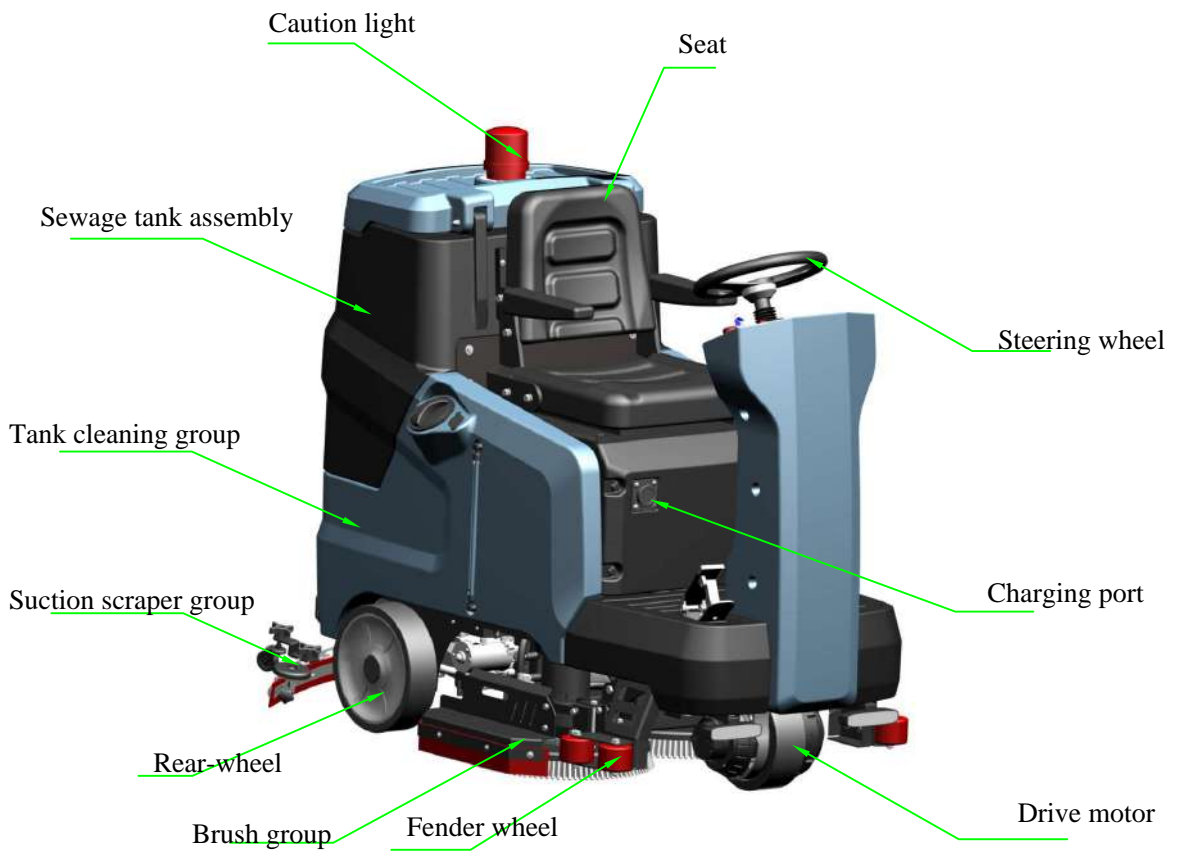

Control and instrumentation

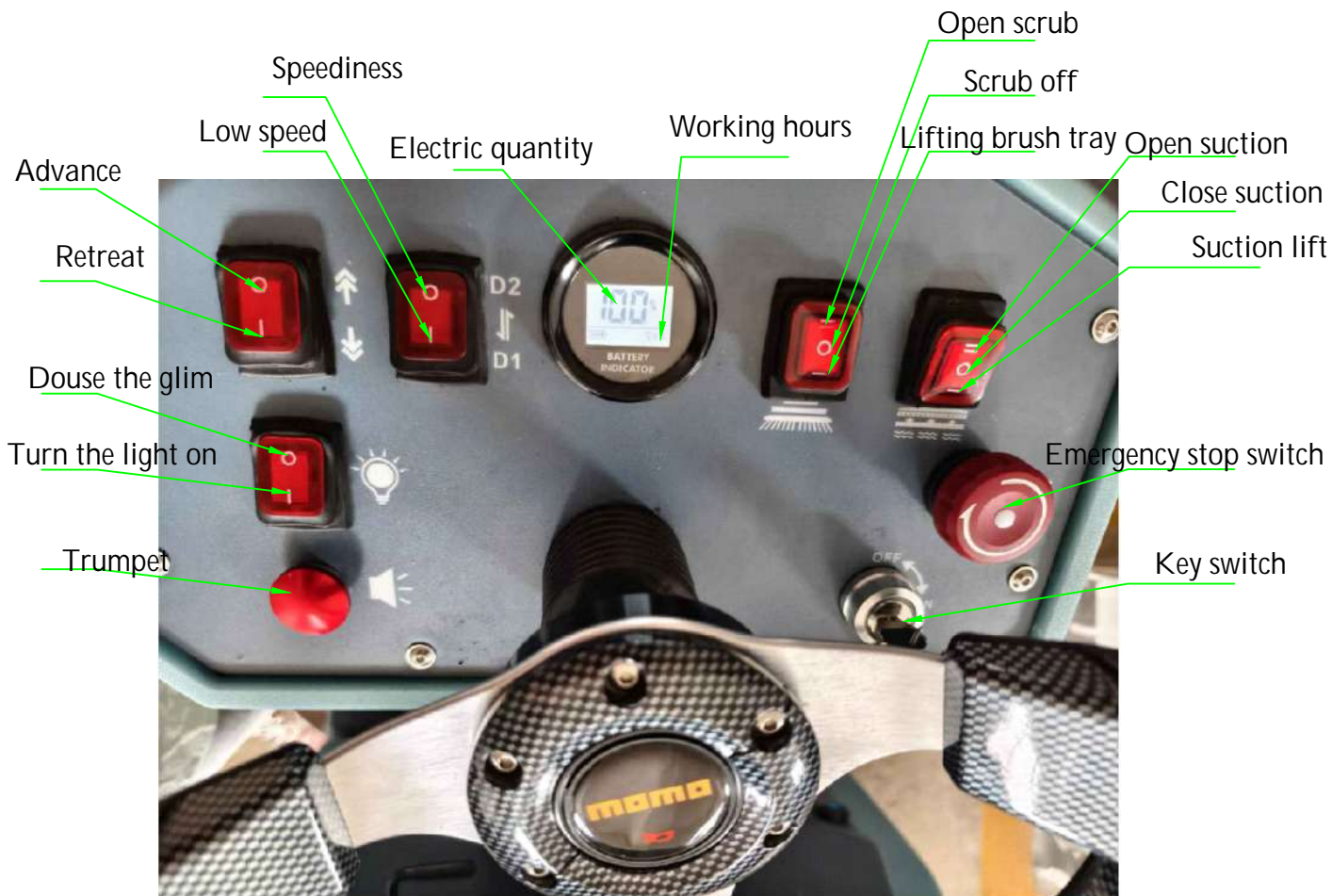

Scram switch: In an emergency, the scram switch button will stop all power to the machine. Press this button to power off the machine. It would be urgent to restart the machine Turn the stop button to the right. Turn the switch to the off position, and then turn it to the on position. (During normal stop operation, do not use the secondary button, which will wear out the brake)

Working principle of machine



The cleaning parts of the machine are: a cleaning water tank, two washing brush trays, a suction scraper, a vacuum suction Electric motors and a sewage tank.

The button on the control panel: controls the scrubbing function of the machine. The suction motor/paddle button will start or turn off the suction motor and lift or lower the paddle.

Steering wheel: Controls the forward/backward route of the machine.

Direction switch: control machine forward or backward.

Accelerator: The speed of the machine can be controlled by different stepping forces, and the release of the accelerator is the brake.

Way of washing ground

The water in the clean water tank (can add cleaning agent) flows to the floor through the clean water valve. The floor scrubbing dish uses the effluent solution to scrub the floor. While the machine is moving forward, the sewage on the floor is cleaned and gathered by the absorbent scraper, and the vacuum absorbent electric machine generates suction force to suck the sewage and garbage into the sewage box.

Machine setting

Install absorbent scraper assembly:

For safety reasons: Leave or service the machine, park on a level surface, turn off the machine and pull out the key.

Install the rear suction under the bracket and tighten the two knobs.

Connect vacuum tube to suction scraper assembly. Use the equipped hose clamps to make the vacuum tube ring as shown.



Install brush tray:

For safety reasons: Leave or service the machine, park on a level surface, turn off the machine and pull out the key. Start the machine, lift up the brush tray assembly (do not start the washing function), lift the side guard plate and open it as shown in the picture, then move the two brush trays respectively under the brush tray buckle on the machine chassis (roughly aligned with the center), and then start the washing function to automatically lower the brush tray assembly and screw the brush tray buckle into the brush tray.



Inject clean water:

For safety reasons: Leave or service the machine, park on a level surface, turn off the machine and pull out the key.

A clean water injection port is provided on the right side of the machine, and a water level pipe and a water level float are arranged beside the injection port.

Specific operation: Open the rubber cover of the water injection port, and inject some water (do not exceed 60). According to the mixing ratio of the cleaning agent used, pour the cleaning agent used into the cleaning tank, and then inject water into the cleaning tank.

Until the water pipe floats to the top.

For safety: When using the machine, follow the mixing ratio and handling instructions on the chemical container.



Before machine operation:

- Check the machine for liquid leakage.
- Check the electrolyte and charge.
- Check whether the seal ring of the tank cover is damaged or worn.
- Check the vacuum fan inlet filter.
- Check brush condition. Remove threads, bindings, plastic wrap or other debris from around the brush. - Check whether the absorbent is damaged or worn, or needs to adjust the deflection.
- Check the suction pipe for debris or obstruction.
- Drain and clean the sewage tank.
- Check that the brakes and steering wheel are working properly.
- Check horn, headlight, warning light can work properly.
- Check maintenance records to determine if machine maintenance is required.

Note: Please plan the cleaning method in advance, and try to make long-term planning arrangements to minimize the downtime and startup times. Do not clean the whole floor or area at once.

Floor washing operation:

1. Please turn on the machine with the key switch.



OFF
ON

2. Turn on headlights (if equipped).



O -OFF
I -ON

3. Respectively start the scrubbing system, suction system.



= -ON
O -OFF
— -UP

4. Press the forward gear, select the speed gear, control the steering wheel, and step on the accelerator to go to the dirty area for work.(B rake function after accelerator release)

O -Advance
I -Retreat



O -Speediness
I -Low speed

Note: If the machine needs to back up during the operation process, the recoil gear must be pressed after the scrubbing system and suction system is turned off, and the steering wheel and accelerator can be operated for backward operation.

Operation

Discharge of sewage

For safety reasons: When discharging sewage, park on a horizontal surface near the sewage discharge area, turn off the machine and pull out the key.

Take off the blowdown pipe behind the machine, hold the pipe head close to the sewer, and slowly unscrew the pipe cover.

After discharge, open the cover of the sewage box and wash down the residual garbage inside the sewage box.

(Large water pressure, do not quickly open the tube cover, do not use the tube mouth to people)



Blow-off pipe

Battery charging

For safety reasons: Before charging the machine, stop the car on the level, turn off the machine and pull out the key.

Stop the machine in a dry and ventilated area, remove the rubber cover of the charging port under the seat of the machine, align the charger and charging socket, plug it in place, and observe the charging indicator light.

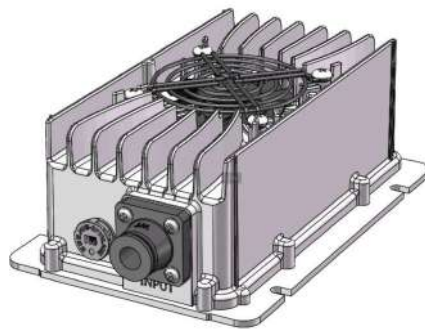

Power display:

If the red light is blinking, the battery capacity is less than 80%. Charging: red light flashing;
The yellow light is blinking, the battery power is 80%;
Full: the green light is on;
The green light is blinking, and the battery is 100%.

No load warning: the traffic light flashes alternately

	Indicator status (“-”)Representative pause ls	Fault warning	Solution
1	Red green Red green Red green	No-load	Check that the charger is properly connected to the battery. The battery voltage is too low
2	Red green Red green Red green	Overvoltage (current) fault	If it reappears after the reboot, Need to return to factory repair
3	Red green red --	The ambient temperature is too high or too low	The ambient temperature is too high or too low
4	Red green - - - -	Charger overheat	Check the ambient temperature of the charger Is it too high?
5	Red green - - - -	Output undervoltage	Return to depot
6	Red green red green red -	The input AC power is abnormal	Check whether the input voltage meets the requirements Whether the plug is in poor contact
7	Red green red --	Any of the above 5 errors - item After five repetitions, you get it Error state	Power on the device again and observe that the indicator is faulty If the status matches items 1 to 5, proceed as follows Its corresponding solution solution

Troubleshooting:

For safety reasons: to leave or service the machine, park it on a horizontal surface, turn it off and pull out the key.

Issue	Cause	Countermeasure
The washing effect is not good	Vacuum suction motor is not turned on	Press the control panel suction system open button
	Press the control panel suction system open button	Replace the absorbent rubber strip
	Displacement of suction paddle	Adjustable paddle
	The suction pipe is blocked	Remove debris from suction pipe
	The joint of the suction pipe falls off	Reconnect both ends of the suction pipe
	The cover of the sewage tank is not tightly covered	Remove debris from the fitting area of the sewage tank cover and cover it well
	The vacuum suction motor does not work because the sewage tank is full	Empty the sewage tank and flush
	Clean water tank is used up	Clean tank filling
	The floor scrubbing dish is badly worn	Wash the dish again
	The battery is low and the motor power is insufficient	Charging

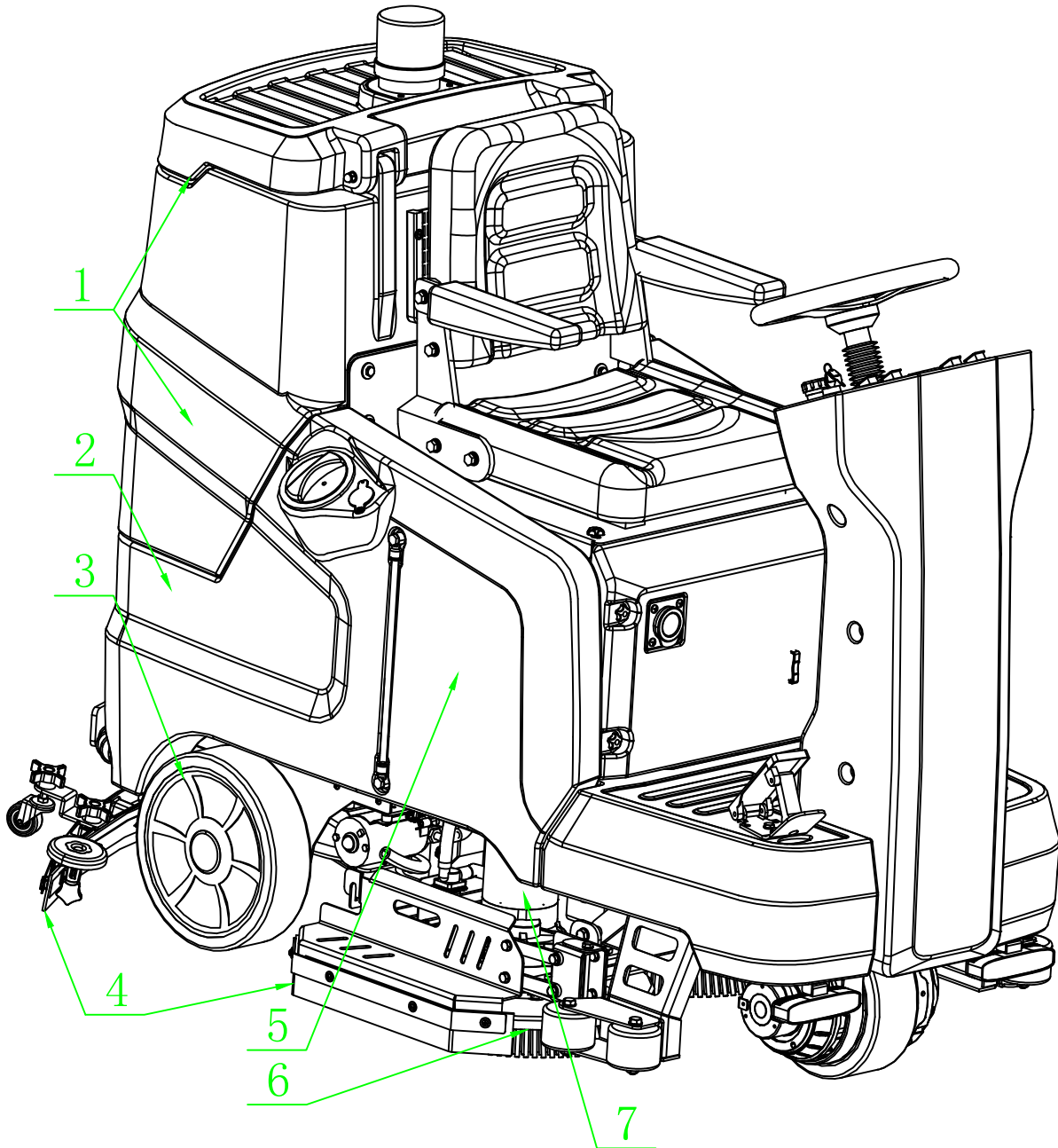

Maintenance table:

For safety reasons: to leave or service the machine, park it on a horizontal surface, turn it off and pull out the key.

The following table indicates the person responsible for each procedure. O= Operator
T= specially trained personnel

Interval period	Person in charge	Check point	Instructions	Routine	Lubricants/liquids
Everyday	O	4	Rear suction strip, side strip	Check for wear	/
		6	Scrubbing	Check for wear	/
		2	Recovery tank	Check whether the garbage filter frame and suction pipe are blocked	/
Weekly	T	5	Battery (lead-acid battery)		DW (Distilled water)
100Hour		1	Vacuum suction motor washer seal ring for sewage tank cover	check Check wear	/
200Hour		5	Battery electrodes and wiring	Check cleanliness	/
500Hour		1	Vacuum suction	Check motor carbon brush (first run Check every 100 hours after 500 hours)	/
		7	Brush motor	Check motor carbon brush (first run Check every 100 hours after 500 hours)	/
		3	Tyre	Check for wear	/

Note: More frequent maintenance is required in dusty extreme conditions.

Battery maintenance:

For safety reasons: When servicing the battery, avoid contact with battery acid.

Battery life is limited by the amount of charge it can carry. For maximum battery life, charge the battery only when the battery indicator is down to one bar. In addition, it is necessary to maintain appropriate electrolyte levels during the life of the battery.

For machines equipped with lead-acid batteries, check the electrolyte level of the batteries weekly.

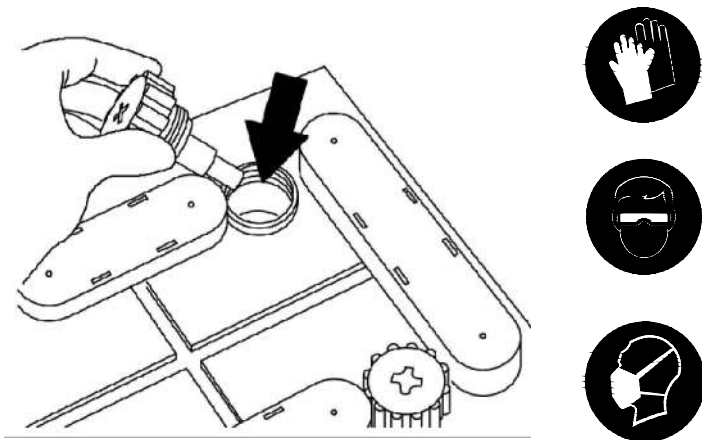

Check connection/cleaning

Every 200 hours of use, check the battery plug for loosening, and use a concentrated solution of baking soda and water to clean the battery surface, including terminals and wire ties. Replace all severely worn cables. Do not remove the cap when cleaning the battery.

Note: Metal objects may short-circuit the battery. All metal objects must be kept away from the battery.

Motor maintenance:

For safety reasons: Leave or service the machine, park on a level surface, turn off the machine and pull out the key. After every 500 hours of operation of the machine, the carbon brush of the vacuum suction motor and the brush plate motor should be checked.

Check every 100 hours after 500.

Vacuum suction motor



Brush motor



Replace the brush plate:

For safety reasons: Leave or service the machine, park on a level surface, turn off the machine and pull out the key. After starting the machine, lift the brush tray assembly, open the side guard plate, hold the brush tray bristles and turn the brush tray counterclockwise, so that the brush tray can fall off on the brush tray buckle. For details about how to install a new brush disk, see "Installing a Brush Disk". After replacement of absorbent strip:

For safety reasons: Leave or service the machine, park on a level surface, turn off the machine and pull out the key.

1. After removing the absorbent strip assembly, turn the knob as shown in the figure counterclockwise (one on each side), and then take out the metal sheet and the front rubber strip successively.



2. Pull out the red retractor as shown in the picture and remove the metal sheet at the end.



3. Finally, remove the remaining metal sheet and the rear adhesive strip



4. Reinstall the new rubber strip according to the above removal steps.

Replace the side strip:

For safety reasons: Leave or service the machine, park on a level surface, turn off the machine and pull out the key. Use a Phillips screwdriver to remove the screws that install the side rubber strip and press the sheet, and replace the rubber strip with a new one.

Adjusted absorbent streak:

For safety reasons: Leave or service the machine, park on a level surface, turn off the machine and pull out the key. After adjustment, make sure that the edge of the absorbent scraper can be completely in contact with the cleaning ground, please make this adjustment on a flat ground:

1. Turn the adjusting screw circled in Figure 1, and visually measure the parallel degree between the absorbent mounting plate circled in Figure 2 and the ground until it is roughly parallel.

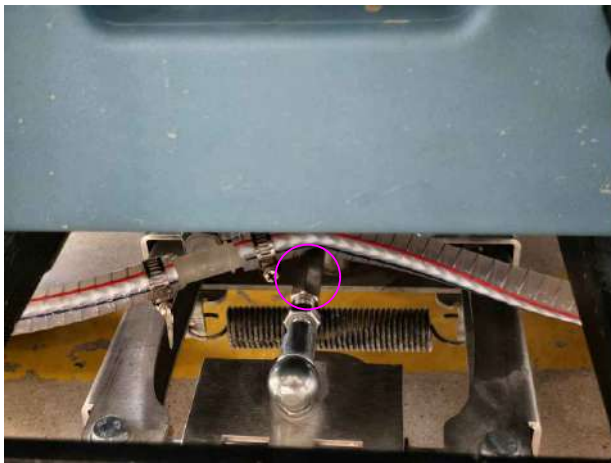

Photo1

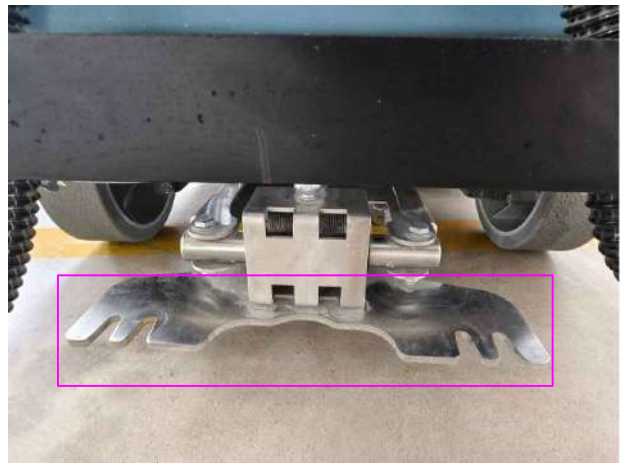

Photo 2

2. By turning the knob and nut in Figure 3, you can adjust the height of the universal wheel, so as to adjust the relative Angle between the suction strip and the ground , until it is approximately 45°.



Photo 3

Sewage tank sealing ring maintenance:

For safety reasons: Leave or service the machine, park on a level surface, turn off the machine and pull out the key. The sewage tank seal ring is located at the bottom of the sewage tank cover. Check the wear and tear of the seal ring every 100 hours.



Tire Maintenance:

For safety reasons: Leave or service the machine, park on a level surface, turn off the machine and pull out the key. Check the wear and tear after every 500 hours:



Transport machine:

For safety reasons: Leave or service the machine, park on a level surface, turn off the machine and pull out the key. When using a truck or trailer to move the machine, be sure to follow the following procedures

1. Raise the absorbent raking and wash the floor

For safety reasons: when loading the machine onto or off a truck or trailer, The water tank must be emptied before loading the machine.

2. Load and unload the machine using the recommended device

For safety: When transporting the machine, load and unload the machine from a truck or trolley using the recommended loading and unloading device.

3. Place the front of the machine against the front of the truck or trailer.

4. Place the machine in the trailer or truck, and lower the washing head and suction scraper.

5. Place obstacles behind each drive wheel to prevent the machine from sliding.

6. Wrap the rope around the fixed arm and then tie it to the trailer or truck to prevent the machine from tilting.

Storage machine:

When storing the machine for a long time, please take the following steps.

1. Drain and clean the water tank and sewage tank, and open the sewage tank for ventilation.

2. Keep the machine in a cool and dry indoor area, and keep the machine away from rain.

3. Take out the battery or charge it every 3 months.

Specification

Machine specifications:

Rated voltage	DC24V	
Work efficiency	5100m ² /h	
Brush pressure	40±5%Kg/cm ²	
Vacuum suction motor power	550W	
Recovery tank	130L	
Solution tank	120L	
Clean absorbent width	880/1110mm	
Gradient	20%	
Noise level	70db	
Net Weight	289KG	
Water jet motor	Rated voltage	DC24V
	Maximum current	3A
	Maximum discharge	5L/MIN
	Rotational speed	1200r/min
	Maximum pressure	0.42Mpa
Solenoid valve	Rated voltage	DC24V
	Inlet pressure	≤0.02Mpa
	Discharge flow	≥3L/MIN
	Fluid temperature	0℃~40℃
	Insulation class	E
	Working life	≥30000 times
Suction scraper push rod motor	Rated voltage	DC24V
	Journey	80mm
	Speed	7mm/s
	Maximum load	1600N
Brush disc push rod motor	Rated voltage	DC24V
	Journey	80mm
	Speed	11mm/s
	Maximum load	3000N
Brush motor	Rotational speed	200rpm
	Power	450W*2
Absorbent scraper	Length	1110mm

Battery	Battery capacity	200A*2
	Battery weight	35KG*4
	Charging time	6~8h
	Continuous working time	4~6h
Recharger	Argument	25A(Aviation plug)
Adhesive strip	Material	rubber
	Length	1110mm
	Breadth	60mm
	Thickness	4mm
Scrubbing	Working diameter	880mm
	quantity	17"*2

Machine dimensions:

